

# SOFTWARE TECHNOLOGY

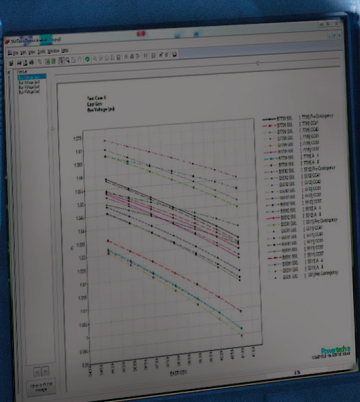

**Powertech**  
The Power of Trust. The Future of Energy.

## MAINTAINING GRID SECURITY

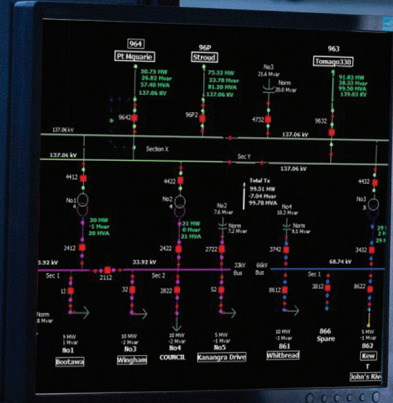
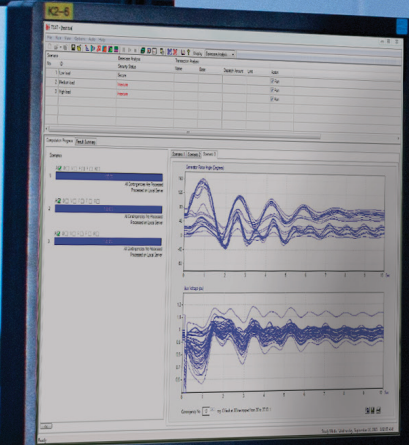
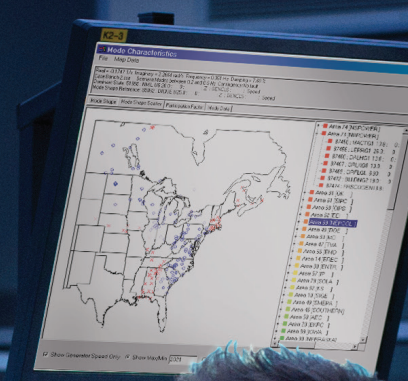
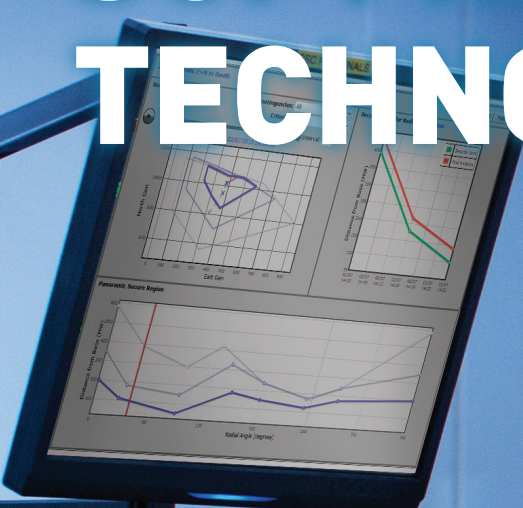

### Analysis tools for off-line and on-line Dynamic Security Assessment

*Maintaining grid security is a fundamental requirement for power system operations and the reliable supply of electricity.*

*Traditionally, dynamic security assessment (DSA) of power systems attempts to ensure system security through analytical studies and simulations for a selected number of forecast system conditions and contingencies. This approach (off-line DSA) continues being used, although increasingly a new approach (on-line DSA) is needed to meet the challenging requirements of system operations in the new environment.*

Powertech's Software Technology Department meets these needs with a comprehensive suite of power system analysis tools, with capabilities for both off-line and on-line DSA.

The Department's flagship product, DSATools™, incorporates leading-edge technologies for the modeling, design, and analysis of power systems. For off-line DSA, the programs may be used to conduct system design, planning, and operation studies involving thermal analysis, voltage stability assessment, reactive power planning, dynamic performance analyses, transfer capacity analysis, and NERC compliancy studies.

The more advanced and unique applications of DSATools™, developed exclusively by Powertech, are for on-line DSA. In this mode, the software is connected directly to a power system's

energy management system (EMS) and assesses the system security in continuous cycles. Using real-time captured system conditions, an on-line DSA system provides system operators with important information about system security limits, types of criteria violations, critical contingencies, and remedial actions needed to prevent system failures.

The Software Technology Department also works closely with Powertech's Power Systems Studies Department, which conducts field testing of power equipment, simulation model validation, and power system studies around the globe. Using this up-to-date, real-world experience, the Software Department designs tools to address new technical problems as they emerge, such as low-frequency oscillations and subsynchronous resonance.



## CONTENTS

- 04** Capabilities
- 05** Products and Services
- 06** Case Study: Deployment of On-line DSA System at ERCOT
- 07** DSATools™ User Base

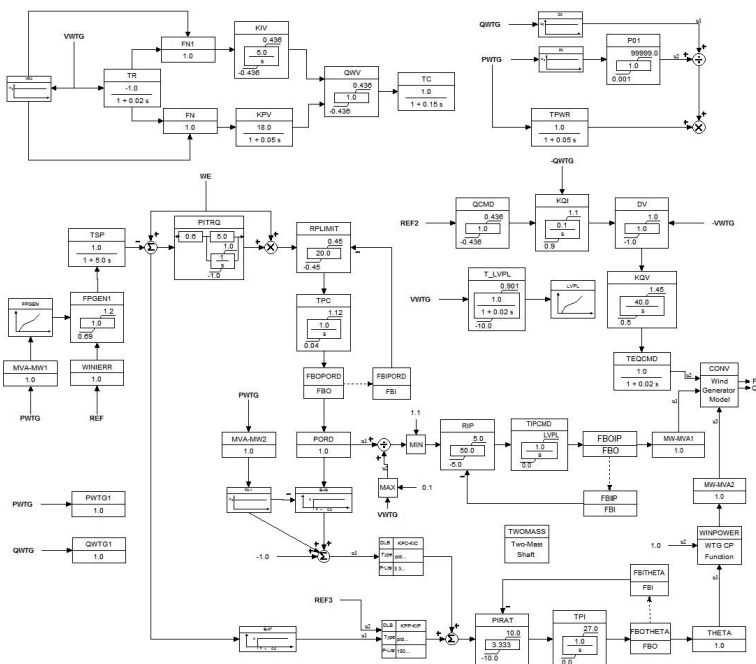

A wind turbine simulation model



## CAPABILITIES

The capabilities of the Software Technology Department derive from the experience and expertise of its staff.

The department's engineers and programmer analysts are responsible for developing and licensing the power system analysis software suite DSATools™ and other programs. The members of the department have 25+ years of experience in power system analysis and software development and extensive backgrounds in research and development, including:

- Theories and methods for power system analysis.
- Development of algorithms for power system computations.
- Development of off-the-shelf software for general applications, and special tools to meet the requirements of individual customers.
- Power system modeling and model development.

- Various types of power system studies—such as IPP studies, remedial action design/validation, under-voltage/under-frequency load shedding coordination, and event reconstruction.
- Standards, policies, and practices used in the power industry—for example, IEEE standards, NERC standards, etc.
- Development of power system application software for various platforms, including Windows, Web, database, etc.

Together, these capabilities enable Powertech to be at the forefront of emerging issues and to design responsive, leading-edge software.

### Other Capabilities:

- **Collaboration with Power Systems Studies Team** – added value through in-house collaboration with Powertech's Power Systems Studies team, which engages in international consulting services in all aspects of power system studies.
- **Base Case Development** – expertise in large-scale custom model development, such as assembling base cases for the US/Canada Eastern Interconnection for NERC/ERAG.
- **International Reach** – international market experience with projects on six continents.
- **Training** – technical training in power systems analysis, NERC-certified training, and custom courses.
- **Collaboration with Technical Communities** – participation in activities from IEEE, CIGRE, NERC, WECC, EPRI, CEATI, etc.
- **R & D Partnership** – collaboration with universities and research institutes for development of innovative solutions and methodologies.

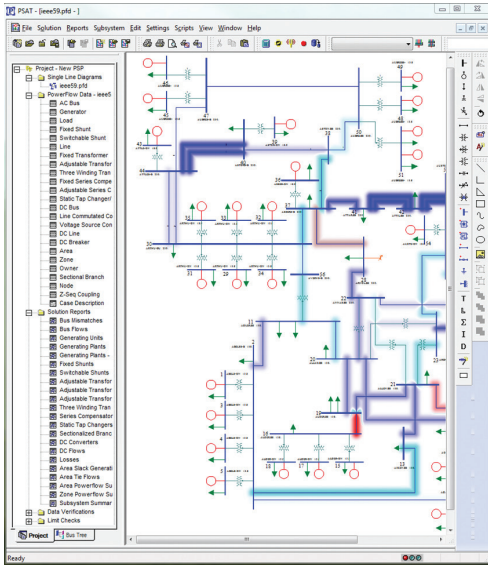

## PRODUCTS AND SERVICES

### Powertech's flagship software product is DSATools™.

DSATools™ is a suite of state-of-the-art power system analysis tools that provides the capabilities for a comprehensive system security assessment, including all forms of stability. The programs are designed for off-line studies, as well as for on-line dynamic security assessment (DSA), when integrated with a power system's energy management system (EMS).

The core modules are complemented by a set of add-on modules for specific applications.

Other products include custom-designed programs such as System Dynamics Database (SDDDB), which is a tool designed for managing dynamic models; DYNRED, for reducing large power system models for static and dynamic performance analysis; and VOB, for visualizing and analyzing power system security boundary.

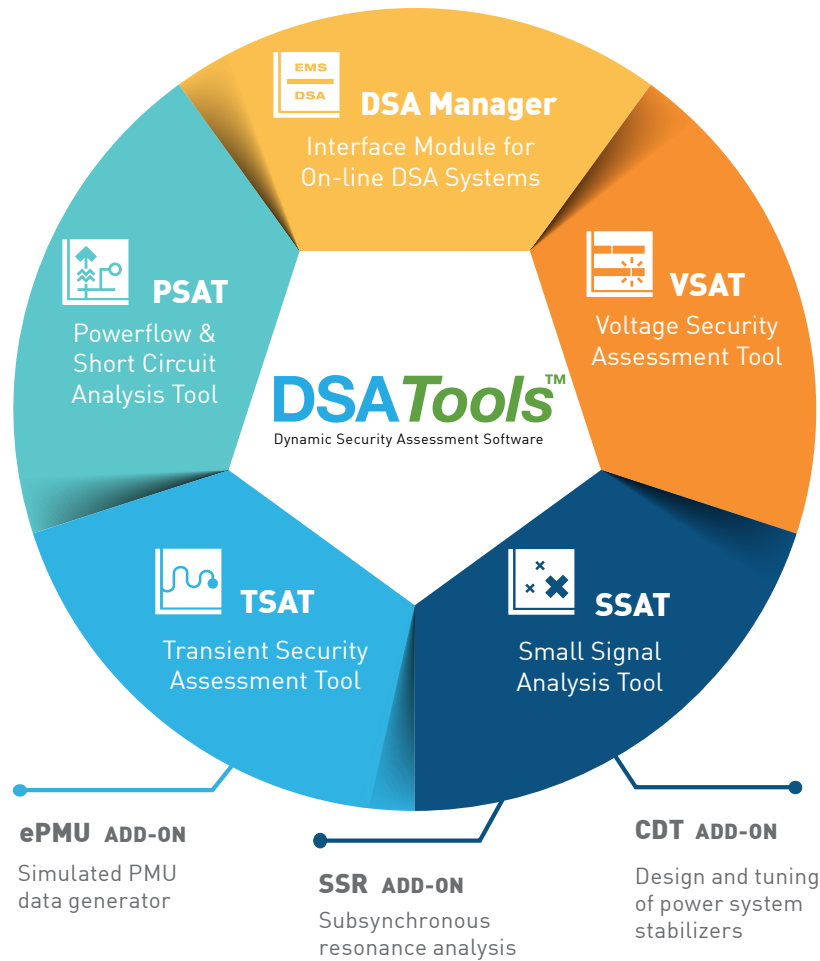

### Key services include:

- **Development and commercialization of the power system analysis software suite DSATools™** – suite of software tools with comprehensive capabilities for voltage, transient, small signal, frequency stability, and SSR etc. assessment.
- **Custom software development** – Software developed to meet targeted needs for NERC, EPRI, and others.
- **Implementation of on-line dynamic security assessment (DSA) systems** – prominent provider of on-line DSA technology, with more than 40 installations worldwide, including seven of nine ISOs in North America.
- **Consulting services** – development of models, design of custom functions, and integration of software.
- **Power system model development** – conventional models for generators (including control system tuning and optimization), loads (such as composite load models), and advanced models for FACTS, HVDC, renewables (wind, solar, etc.), batteries, and special protection systems.
- **Software support and training** – customer assistance in software deployment and training of staff.

## CASE STUDY: Deployment of On-line DSA System at ERCOT

### Real-time information to improve grid security

*The Electric Reliability Council of Texas Inc. (ERCOT) serves as the Independent System Operator (ISO) for most of the state of Texas in the United States, and manages the flow of electric power to 23 million customers. ERCOT schedules power on an electric grid that connects 41,500 miles of transmission lines and more than 550 generation units.*

*The ISO has experienced voltage and transient stability problems related to high power flow transferred from remote generation sites to large load centers.*

To assist operators in addressing these issues, ERCOT installed an on-line DSA system in 2000 and upgraded it in 2012. The system consists of two functional modules: voltage security assessment (using VSAT) and transient security assessment (using TSAT).

ERCOT's use of DSATools™ demonstrates how the software can provide real-time information to improve grid security and optimize system operation for electricity market benefits.

Running every 15 minutes, the on-line DSA system performs voltage security assessment for seven study scenarios and transient security assessment for one study scenario. Each study scenario calculates the security limit on the pre-defined transfer interface, which is the maximum active power

(MW) transferred through the interface before voltage or transient insecurity happens. The calculated security limits provide system operators with a measure of reliability margin from the current operating condition to potential instability, and an approach to use the market tools to prevent the system from getting close to an unstable state.

Prior to the use of the on-line DSA system based on DSATools™, power transfer limits on ERCOT's West-to-North interface were based on annual off-line engineering studies. The on-line VSAT and TSAT modules automatically determine the transfer limits every 15 minutes using the real-time system data. ERCOT estimated that by using the on-line TSAT technology alone, it saved US\$27 million in 2011 in congestion management cost\*.

\* Source: presentation made by ERCOT President and CEO Trip Doggett on April 9, 2012 to the Texas Renewable Energy Industries Association.



ERCOT service area

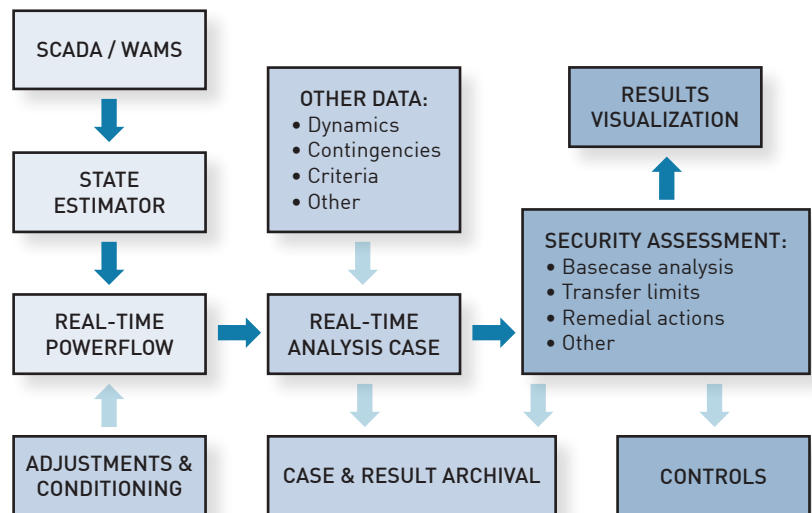

Online DSA flowchart

## DSATOOLS™ USER BASE

DSATools™ has a broad user base, which includes seven of the nine ISOs in North America and spans across six continents, encompassing some of the largest and most technologically advanced utilities and grid operators in the world. Powertech has issued over 200 commercial licenses with more than 4,700 application seats.



On-line DSA systems in U.S. / Canada

Worldwide DSATools™ users

## SELECTED DSATOOLS™ USERS



# THE POWERTECH ADVANTAGE

Powertech Labs Inc. is one of the largest testing and research laboratories in North America, situated in beautiful British Columbia, Canada. Our 11-acre facility offers 15 different testing labs for a one-stop-shop approach to managing utility generation, transmission and distribution power systems.



Powertech is home to a broad range of scientists, engineers, and technical specialists, with capabilities in electrical testing, cable condition assessment, mechanical and materials engineering, software technologies, power system studies, chemical analysis, gas systems engineering, and smart utility services. These skilled researchers have decades of collective and real-world experience and often work in cross-departmental teams to investigate, diagnose and solve complex problems.

As an independent, third-party testing facility, we adhere to the **highest** laboratory (**ISO 17025**), quality (**ISO 9001**) and environmental

(**ISO 14001**) management standards. Many of our scientists and engineers chair or participate in various standards committees within their fields of expertise. Additionally we have the capabilities to derive and develop **non-standard testing** methods and setups required to test product prototypes and perform forensic analysis.

Outside of the utilities industry, Powertech provides routine **testing** capabilities, product **development**, research and **consulting** services to support an array of industrial-type operations, electrical equipment manufacturers and automotive original equipment manufacturers.

